

Atmos[®] HP - Diaphragm gas meter

Two-pipe Diaphragm gas meter HP G6A



Solid build quality, high accuracy, safety and a series of advanced technical details make the Atmos[®] diaphragm gas meter a high-grade measuring instrument. The Diaphragm gas meter is available in size G6. The meter is characterized by precise measurements, a constant measuring stability, a long life and high reliability. Thanks to the use of high-grade materials the diaphragm gas meter is resistant to corrosion.

The gas meter is suitable for various gas media. The integrated calibration system coordinates the movement of the valves in relation to the optimum gas flow. The excellent linearity of the error curve is guaranteed even at low flow rates. Due to the optimum rotating characteristics of the valves the Qmin value remains stable and the gas meter is resistant to contamination.

The Atmos[®] HP-diaphragm gas meter meets the requirements of the EN1359:1998/A1:2006 and OIML R137-1 (2012) standards.

Performance characteristics

- Approved in accordance with MID by NMI
- Integrated system to adjust the error curve
- Die-cast aluminum housing for maximum corrosion resistance
- Starting flow < 1 dm³/h
- Working temperature range: -25 °C to +55°C
- Max operating pressure: 1.5 bar
- Long-term stability due to usage of high-quality diaphragms
- Optional: reverse flow preventer

Sizes:

HP G6A : 0.06 m³/h to 10 m³/h

Gas media:

- Natural gas
- Town gas
- Biogas
- Liquid gas
- Methane gas

Housing material:

Die-cast aluminum

Technical data Atmos® HP G6A

| | | | |
|----------------------------|---|-----------------------|----------------|
| Type | | | HP G6A |
| Nominal flowrate | Q_n | m ³ /h | 6 |
| Maximum flowrate | Q_{max} | m ³ /h | 10 |
| Minimum flowrate | Q_{min} | m ³ /h | 0.06 |
| Maximum operating pressure | | bar | 1.5 |
| Maximum permissible errors | $0.1 Q_{max} \leq Q \leq Q_{max}$ $Q_{min} \leq Q < 0.1 Q_{max}$ | | ± 1.5% ± 3% |
| Max. pressure loss | | mbar | ≤ 2 |
| Display range max. | | m ³ /h | 99999.9998 |
| Display range min. | | m ³ /h | 0.0002 |
| Accuracy class | class | | 1.5 |
| Cyclic volume | | dm ³ | 2.5 |
| Pulse value | | m ³ /pulse | 0.01 |
| Weight | | kg | 3.1 |

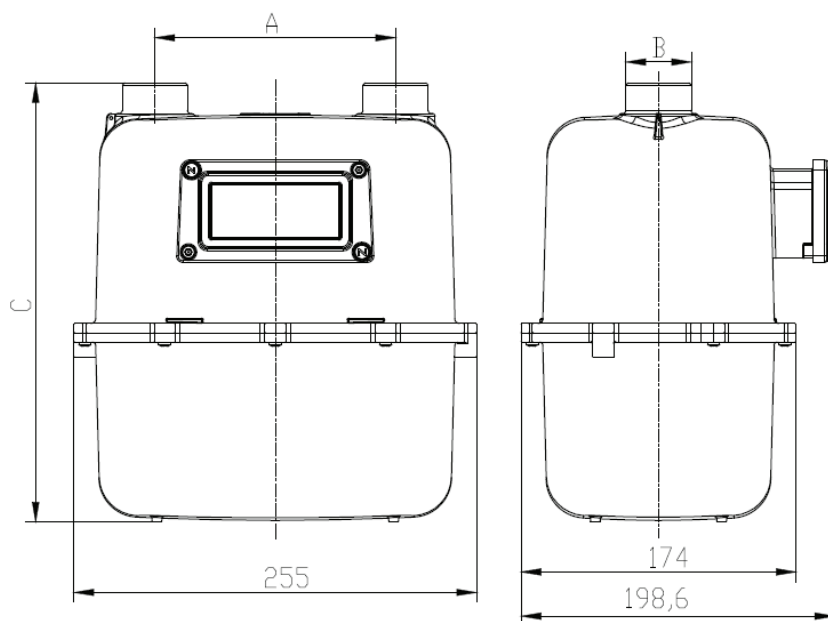

Dimensions Diaphragm gas meter Atmos® HP G6A

| | | | | | |
|---|------|--------------|------|--------|---------|
| A | [mm] | 152.4 ± 0.30 | | | |
| B | | G1B | G1¼B | NPT 1" | NPT 1¼" |
| C | [mm] | 279 | | | |